

PER INFORMAZIONI PIÙ DETTAGLIATE RIVOLGERSI AL CONCESSIONARIO DI ZONA - FOR FURTHER INFORMATION PLEASE KINDLY APPLY TO OUR DEALERS

**pag. 1** MOTORE 2T - 2 STROKE ENGINE

**pag. 2** MOTORE 2T 2014 - 2014 2 STROKE ENGINE

**pag. 3** MOTORE 2T 2002 - 2001 2 STROKE ENGINE

**pag. 4** MOTORE 2T 2004 - 2004 2 STROKE ENGINE

**pag. 5** RICAMBI CAMBIO BIMARCIA/FRIZIONE 3G/CILINDRO MOTARD 70  
SPARE PARTS FOR 2 GEAR ENGINE/3G CLUTCH/70 MOTARD CYLINDER

**pag. 6** MOTORE XP 4T 110 c.c. - XP 4T 110 c.c. ENGINE

**pag. 8** RICAMBI KIT FRIZIONE - CLUTCH KIT PARTS

**pag. 9** MOTORE XP 4T 125 c.c. (fino al telaio n°0229) - XP 4T 125 c.c. ENGINE (up to frame no. n°0229)

**pag. 11** MOTORE XP 4T 125 c.c. (dal telaio n°0230) - XP 4T 125 c.c. ENGINE (from frame no. n°0230)

**pag. 14** MOTORE XP 4T 50 c.c. - XP 4T 50 c.c. ENGINE

**pag. 16** MOTORE XP 4T 150 c.c. - XP 4T 150 c.c. ENGINE

**pag. 18** MOTORE XP 65 R (fino al telaio n° 162) - XP 65 R ENGINE (up to frame no. ° 162)

**pag. 20** MOTORE XP 65 R 2008 (dal telaio n° 163) - XP 65 R 2008 ENGINE (from frame no. 163)

**pag. 22** RICAMBI CARBURATORE POLINI CP - CP POLINI CARBURETOR SPARE PARTS



**CLICCA PER ACQUISTARE**  
**CLICK TO BUY**



**CONTATTA I RIVENDITORI**  
**CONTACT OUR DEALERS**

- Caratteristiche tecniche ed estetiche possono essere soggette a modifiche senza preavviso.

- Destinate esclusivamente ad uso agonistico sportivo. Ne è vietato l'uso su strada pubblica.

© POLINI MOTORI SPA, TUTTI I DIRITTI RISERVATI. I CONTENUTI DI QUESTO CATALOGO POSSONO ESSERE UTILIZZATI LIBERAMENTE A PATTO DI CITARE LA FONTE ED IL COLLEGAMENTO ALLE PAGINE INTERESSATE.

- Specifications and esthetic characteristics are subject to be changed without notice.

- They are intended solely for competition-sports usage. Use on public highways is prohibited.

© POLINI MOTORI SPA, ALL RIGHTS RESERVED. THE CATALOGUE CONTENTS CAN BE FREELY USED ON CONDITION THAT THE SOURCE AND THE LINK TO THE INTEREST PAGES ARE QUOTED.

# MOTORE 2T - 2 STROKE ENGINE

MOTORE COMPLETO MONOMARCIA  
 SERIE GUARNIZIONI MOTORE  
 SERIE GUARNIZIONI CILINDRO  
 ★ SERIE PARAOLI MOTORE Ø15  
 ● COPPIA CARTER MOTORE CON CUSCINETTI E PARAOLI Ø15  
 SERIE VITI PER MOTORE

ARIA	H <sub>2</sub> O
144.002.003	144.002.003
144.034.001	144.034.002
144.034.003	144.034.004
144.065.001	144.065.003
144.070.001	
144.305.001	144.305.002

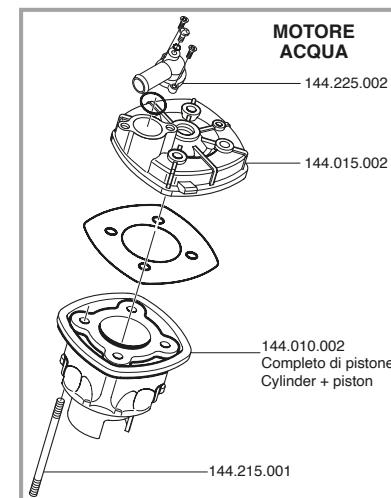
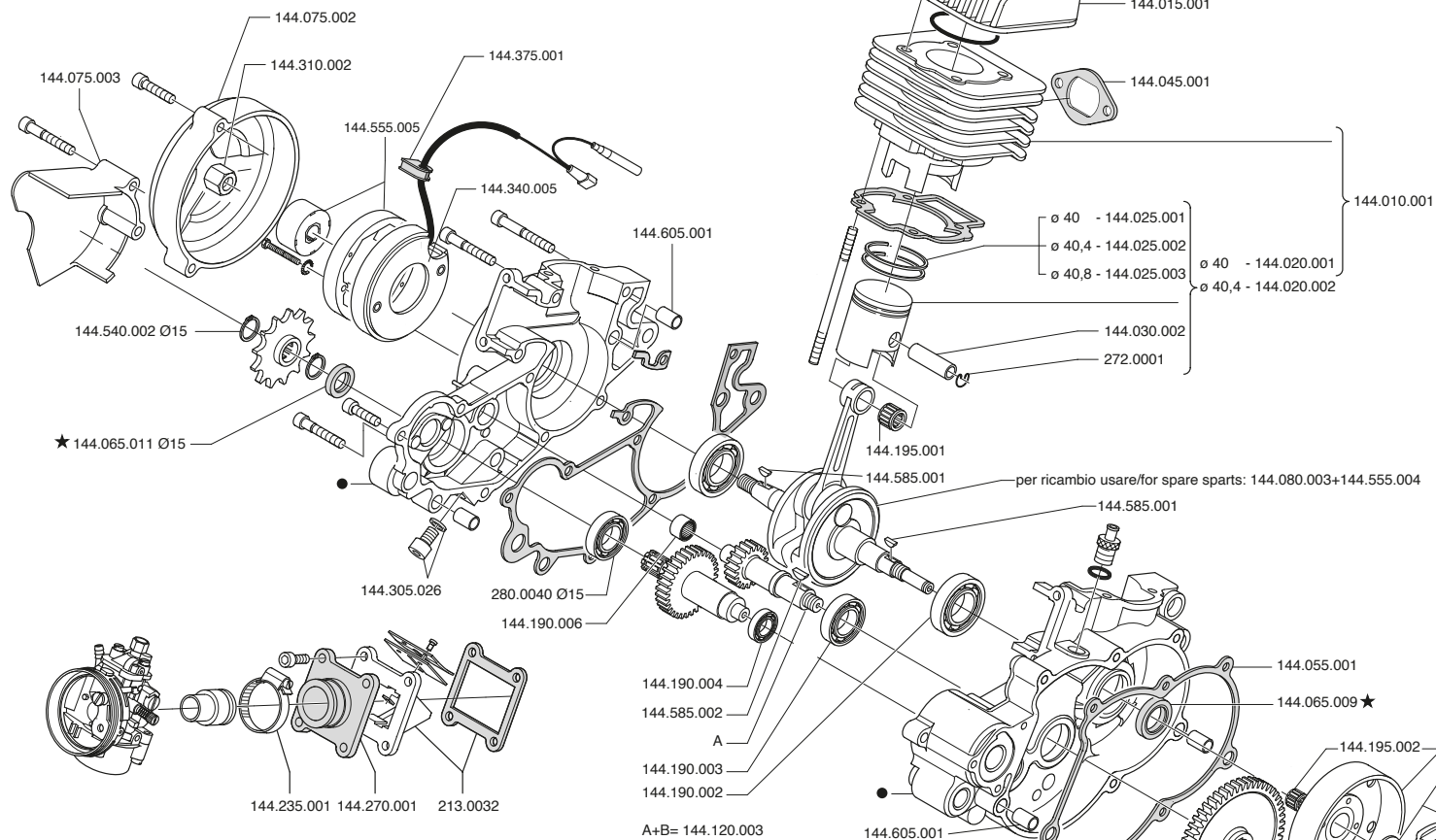

- △ Cod. 143.255.001  
Set molle (ø filo: 1,6 - 2,3 - 2,3)
- Cod. 144.705.003
- Cod. 144.705.002

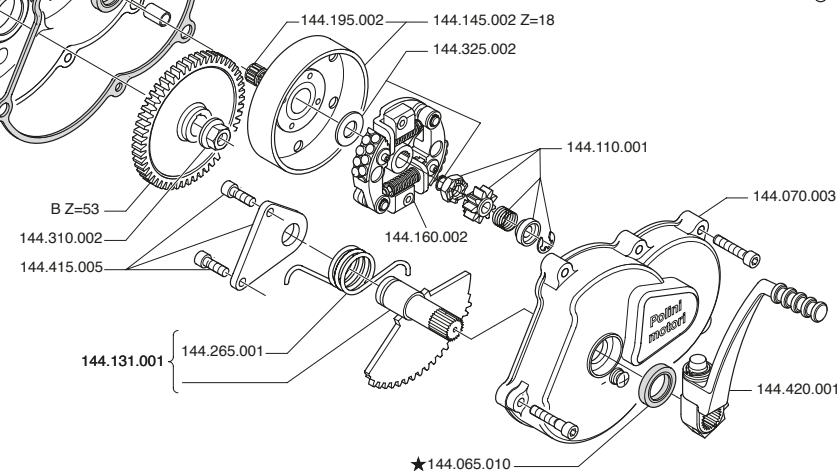
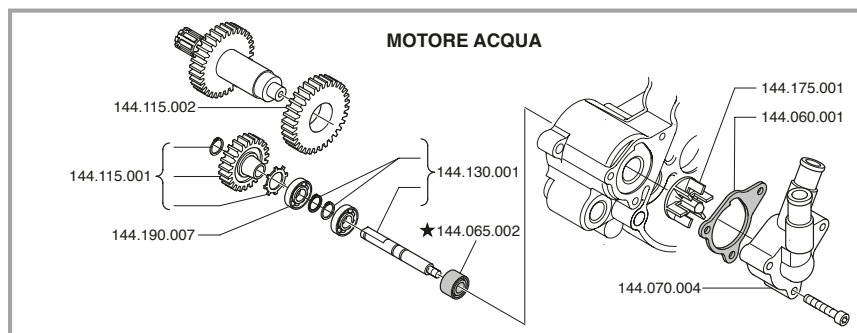
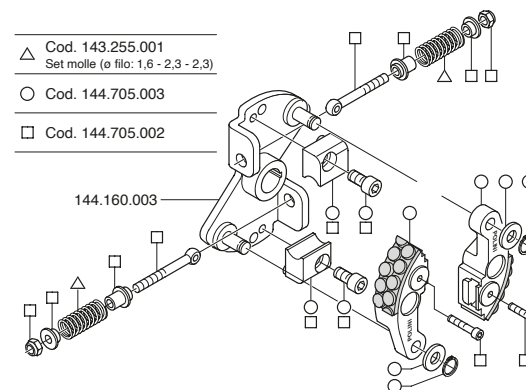

# MOTORE 2T 2014 - 2014 2 STROKE ENGINE

MOTORE COMPLETO MONOMARCIA  
 SERIE GUARNIZIONI MOTORE  
 SERIE GUARNIZIONI CILINDRO  
 ★ SERIE PARAOLI MOTORE Ø17  
 ● COPPIA CARTER MOTORE CON CUSCINETTI E PARAOLI Ø17  
 SERIE VITI PER MOTORE

ARIA	H <sub>2</sub> O
144.034.001	144.002.003
144.034.003	144.034.004
144.065.007	144.065.008
144.070.005	144.070.006
144.305.001	144.305.002

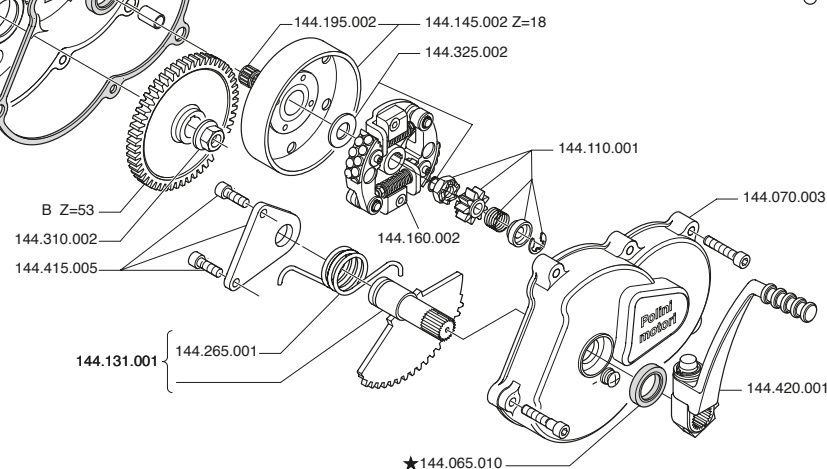
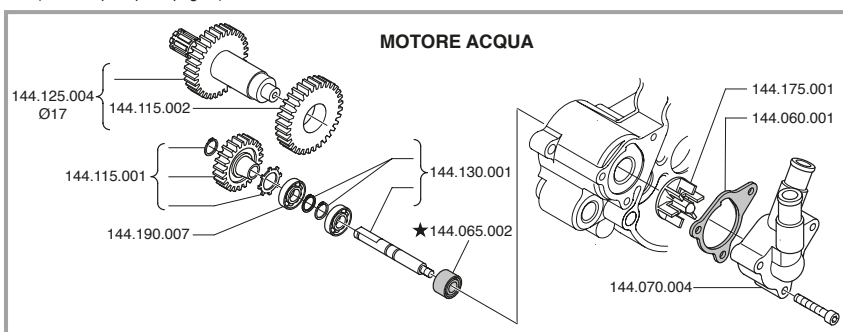
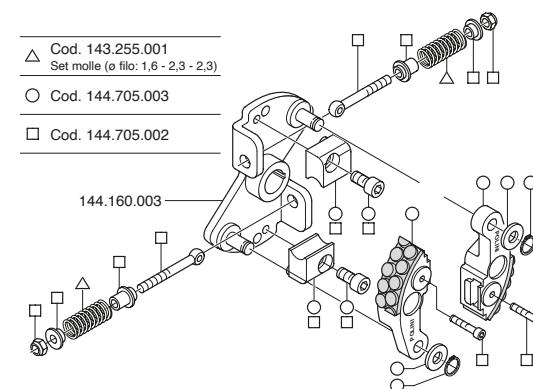
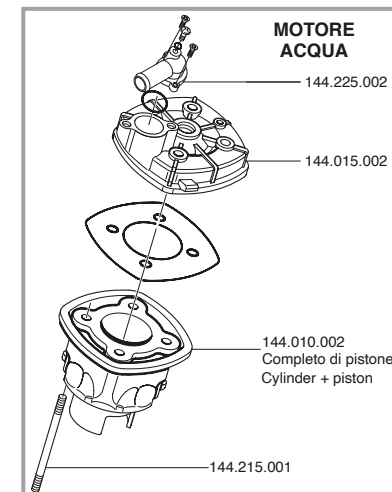
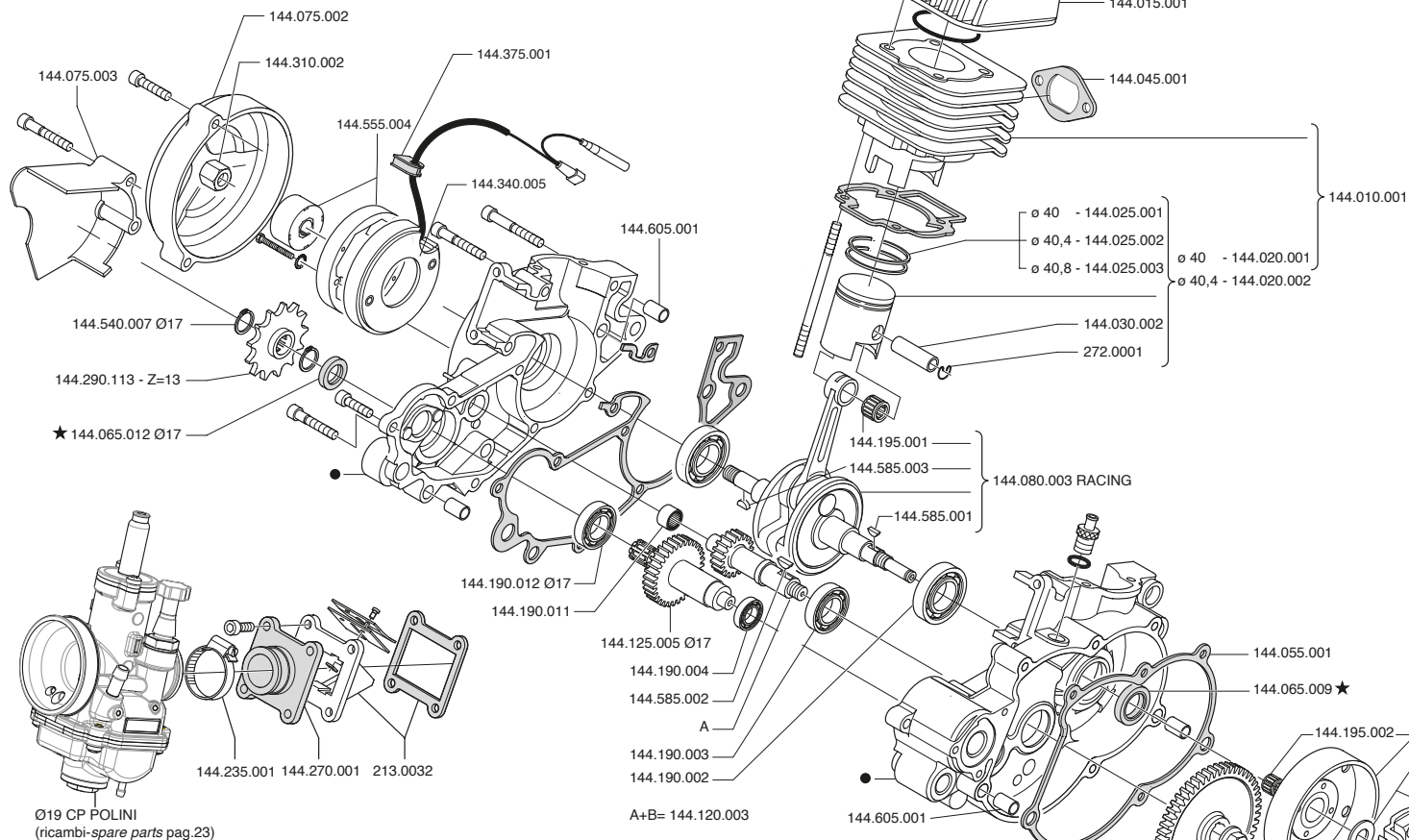

# MOTORE 2T 2002-2002 2 STROKE ENGINE

- \* ACCENSIONE COMPLETA 144.004.012
- SERIE GUARNIZIONI MOTORE 50 C.C. 144.034.007
- SERIE GUARNIZIONI CILINDRO 50 C.C. 144.034.005
- ★ SERIE PARAOLI MOTORE Ø15 144.065.003
  
- SERIE VITI PER MOTORE 144.305.002
- ACCENSIONE COMPLETA (SELETTA) 144.004.011

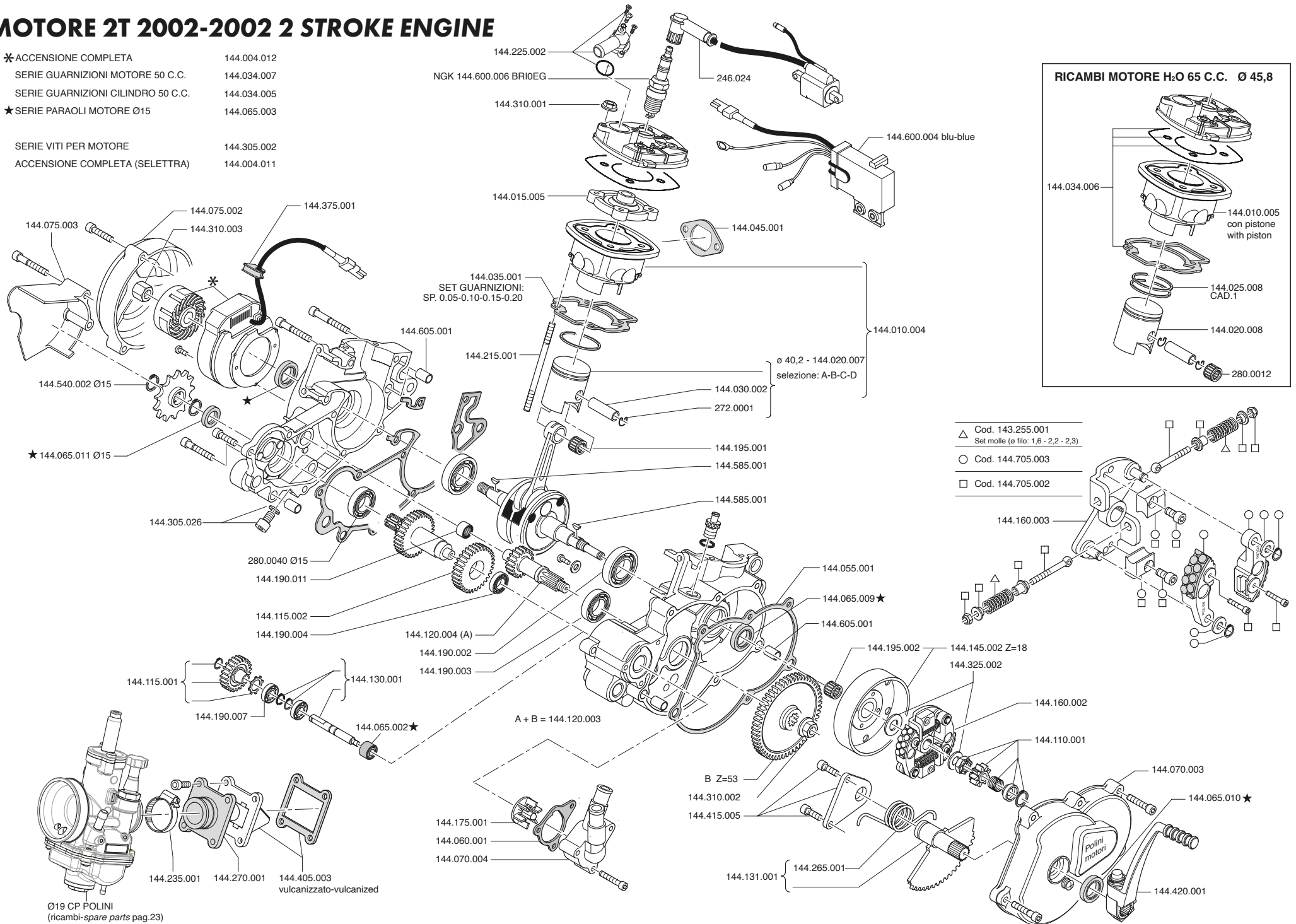

**RICAMBI MOTORE H<sub>2</sub>O 65 C.C. Ø 45,8**

- 144.034.006
- 144.010.005 con pistone with piston
- 144.025.008 CAD.1
- 144.020.008
- 280.0012

△ Cod. 143.255.001  
 Set molle (ø filo: 1,6 - 2,2 - 2,3)

○ Cod. 144.705.003

□ Cod. 144.705.002

- 144.160.003
- 144.195.002
- 144.145.002 Z=18
- 144.325.002
- 144.160.002
- 144.110.001
- 144.070.003
- 144.065.010 ★
- 144.420.001

Ø19 CP POLINI  
(ricambi-spare parts pag.23)

# MOTORE 2T 2004 - 2004 2 STROKE ENGINE

- SERIE GUARNIZIONI MOTORE 50 C.C. 144.034.007
- SERIE GUARNIZIONI CILINDRO 50 C.C. 144.034.005
- ★ SERIE PARAOLI MOTORE Ø17 144.065.008
- COPPIA CARTER MOTORE CON CUSCINETTI E PARAOLI 144.070.006
- SERIE VITI PER MOTORE 144.305.002

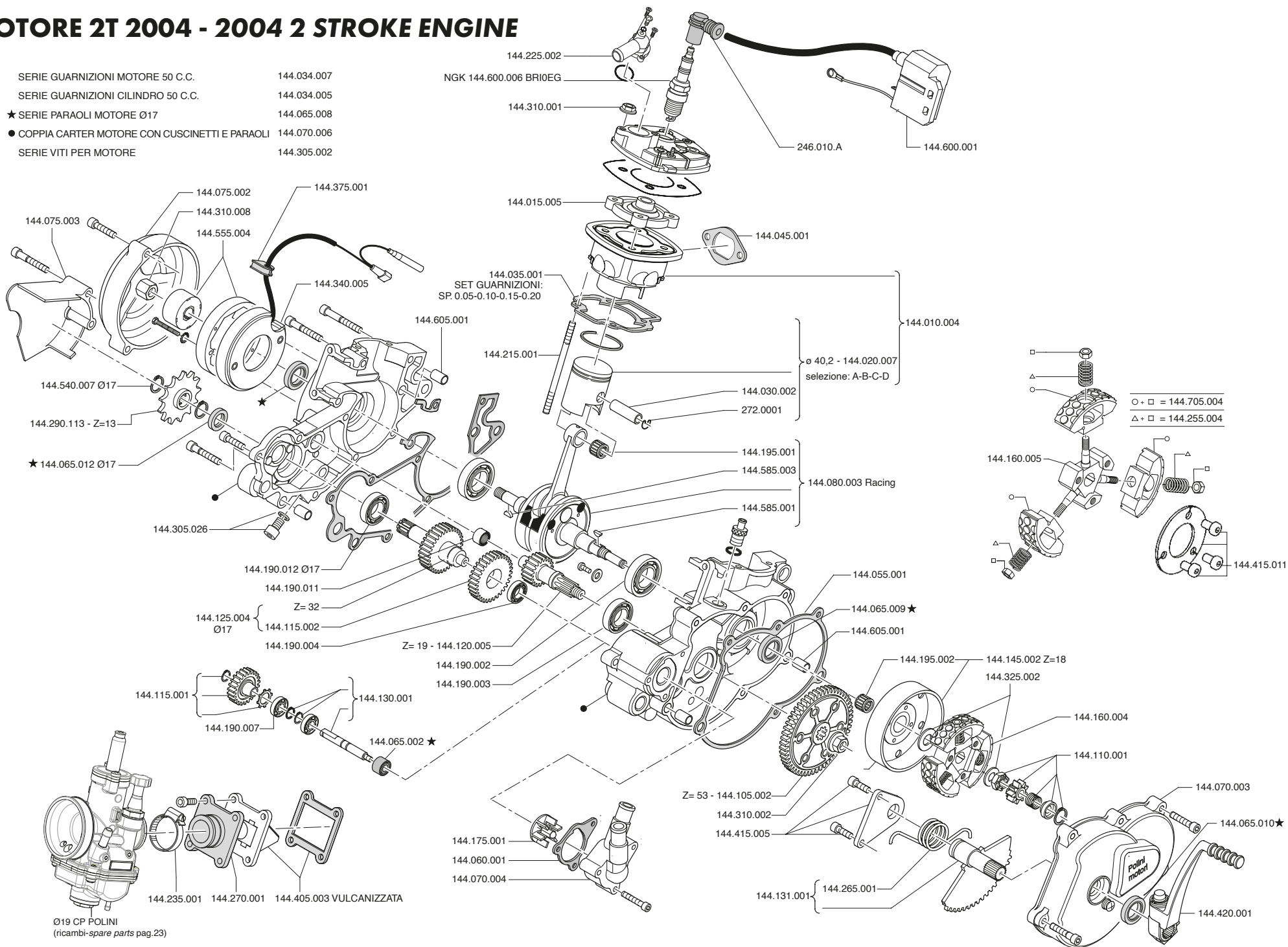

## RICAMBI CAMBIO BIMARCIA 2-SPEED GEAR SPARE PARTS

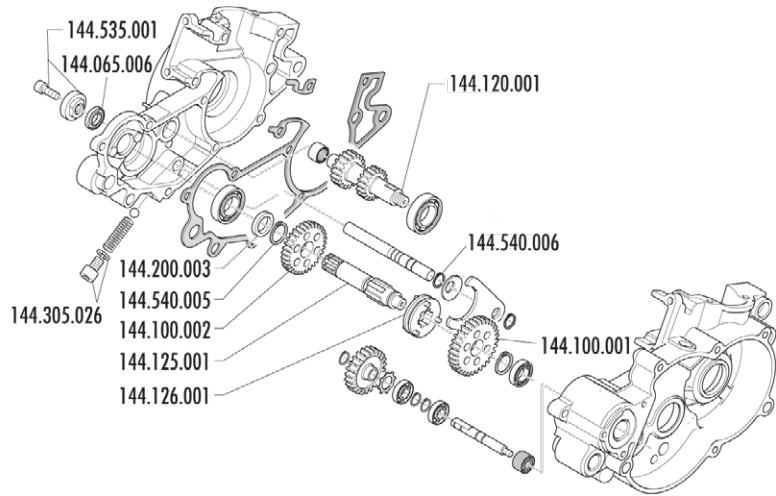

## FRIZIONE 3G - 3G CLUTCH

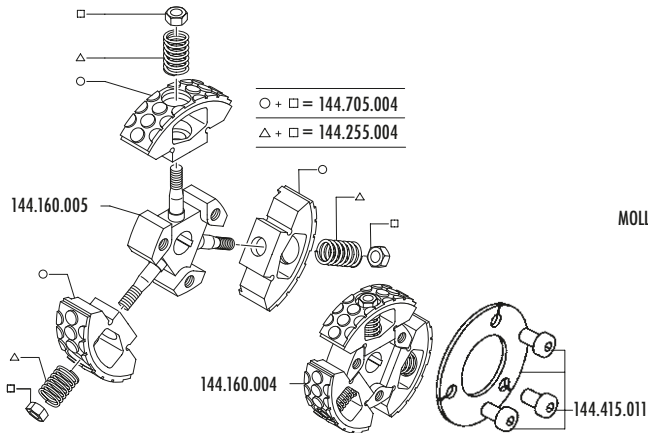

CHIAVE  
REGOLAZIONE  
MOLLE 144.695.005



CHIAVE FERMO  
144.695.006



## MOTARD 70 c.c.

Ø 47,4

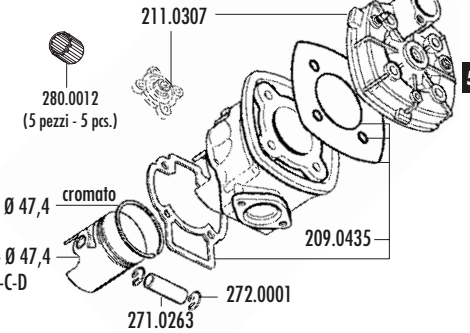
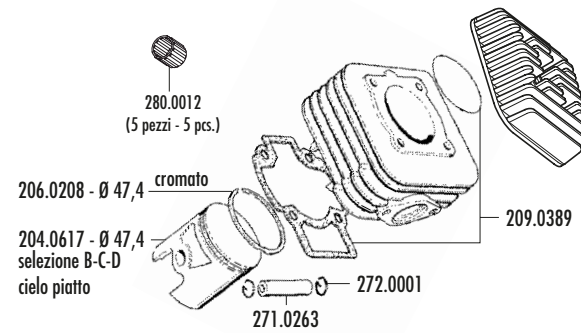

Ø 47,6

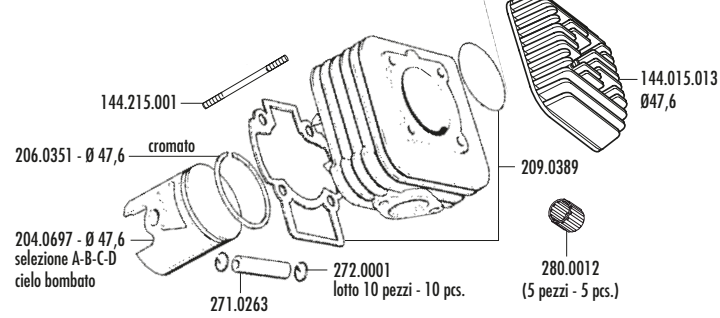

## KIT 144.440.008 - DELL'ORTO VHST Ø28 XP4 110



# XP 4T 110 c.c.

## TESTA - COLLETTORE ASPIRAZIONE - CARBURATORE HEAD - INTAKE MANIFOLD - CARBURETOR

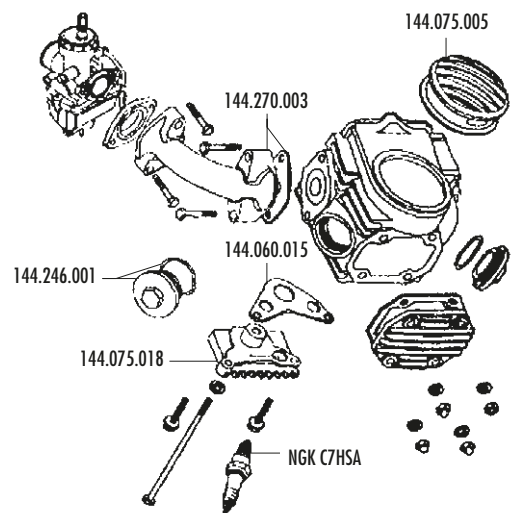

## ALBERO A CAMME - VALVOLA CAM SHAFT - VALVE

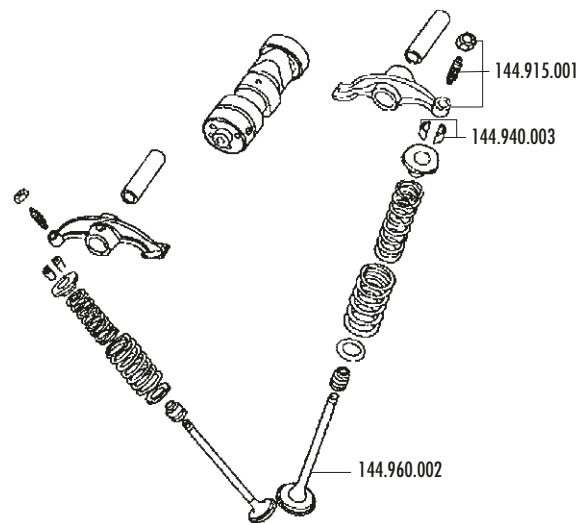

## TESTA - CILINDRO HEAD - CYLINDER

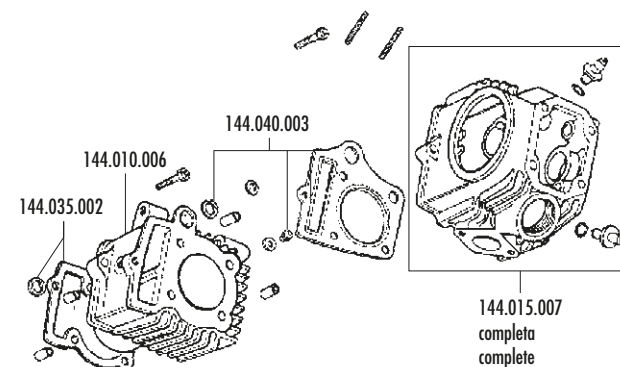

## CARTER MOTORE ENGINE CRANKCASE

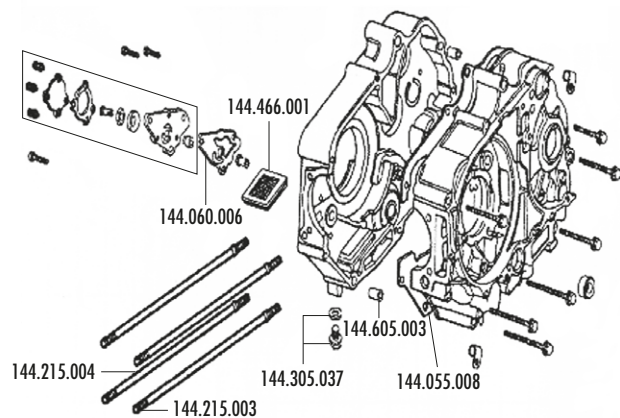

## CATENA DI DISTRIBUZIONE - TENDICATENA GEARING CHAIN - CHAIN TIGHTENER

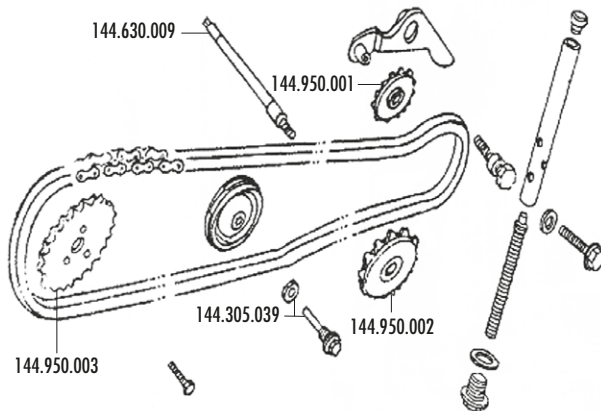

## ALBERO MOTORE - CRANKSHAFT

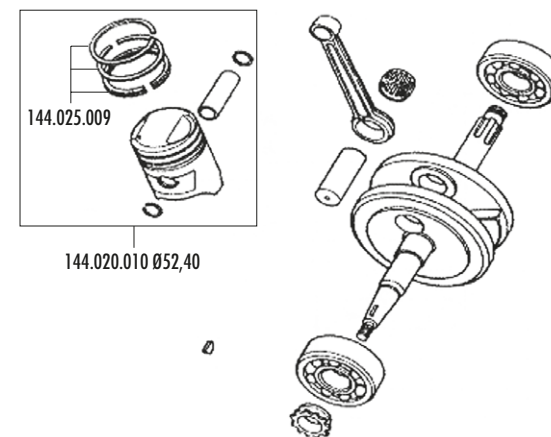

# XP 4T 110 c.c.

## AVVIAMENTO STARTER

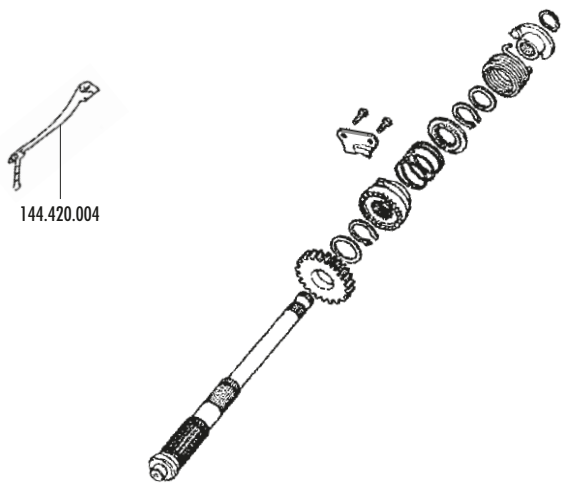

## CARTER LATO FRIZIONE CLUTCH SIDE CASING

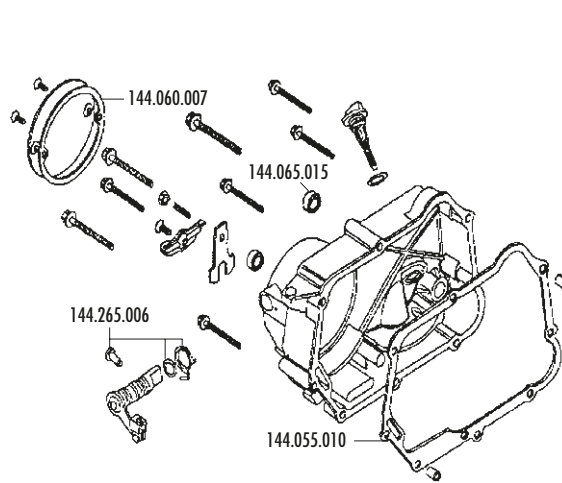

## VOLANO - FLYWHEEL

BOBINA - COIL 144.600.012  
 CENTRALINA - CDI 144.600.013  
 CABLAGGIO - WIRING 144.600.001

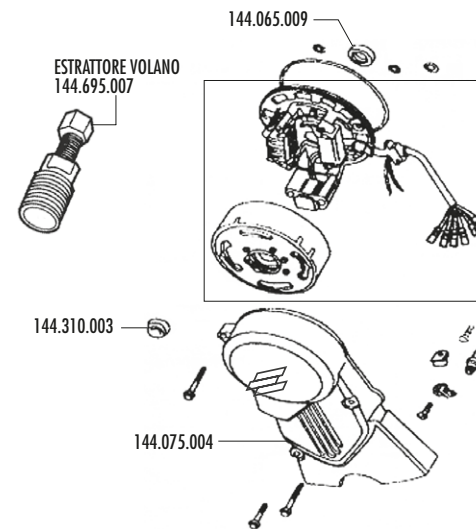

## TRASMISSIONE TRANSMISSION

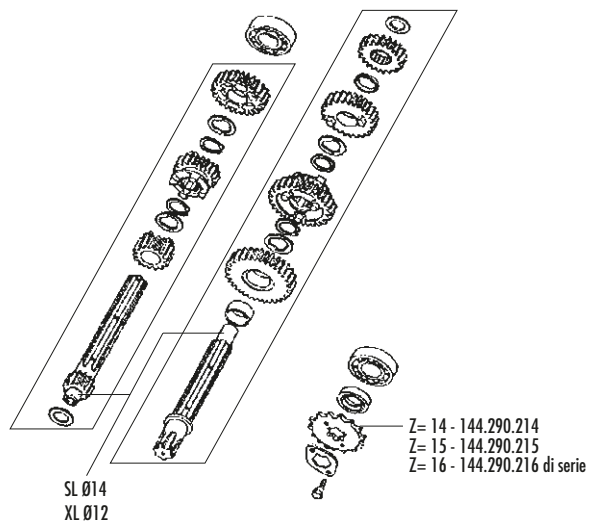

## FRIZIONE CLUTCH

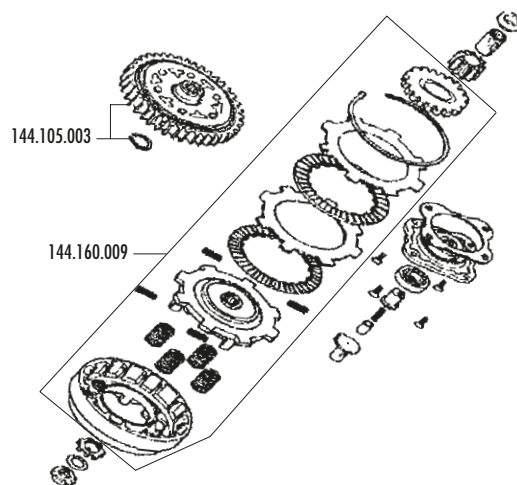

## CAMBIO SHIFT

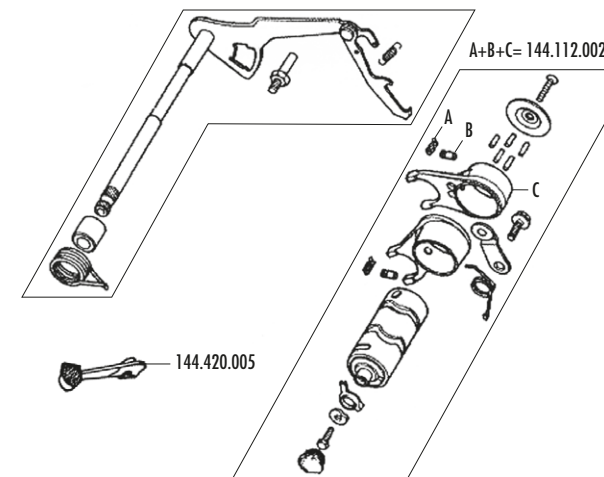



**144.004.020 KIT FRIZIONE XP 4T - XP 4T CLUTCH KIT**  
**144.004.024 KIT FRIZIONE XP 4T NEW - NEW XP 4T CLUTCH KIT**

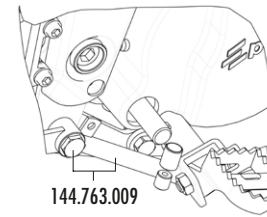
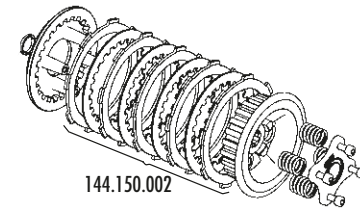
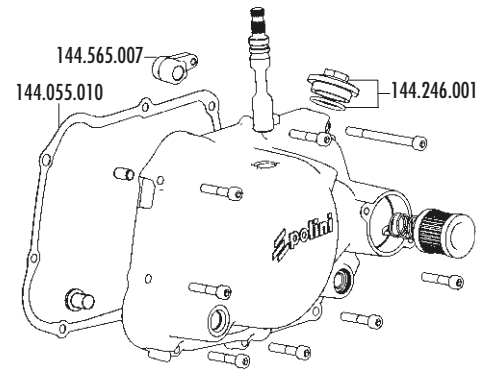

**COPERTURA TESTA  
HEAD COVER**

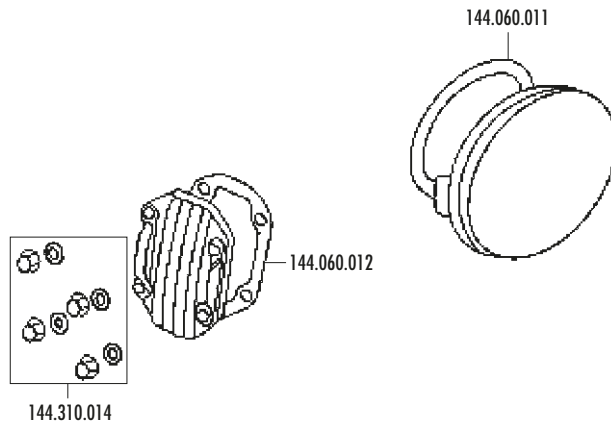

**CILINDRO  
CYLINDER**

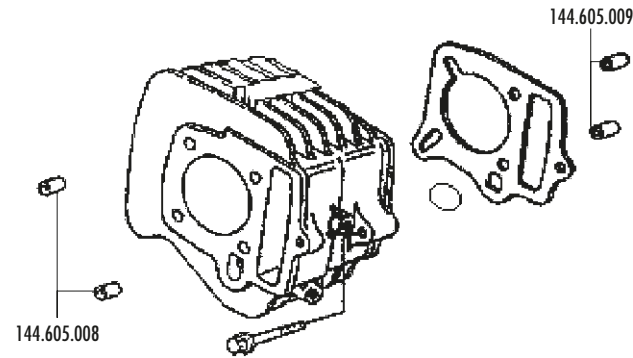

**XP4 125 c.c.  
fino al telaio - up to frame  
n° 0229  
(Gennaio - January 2007)**

**MAGNETE  
MAGNETO**

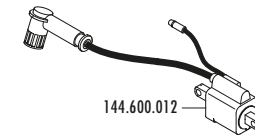

**CARTER MOTORE  
ENGINE CRANKCASE**

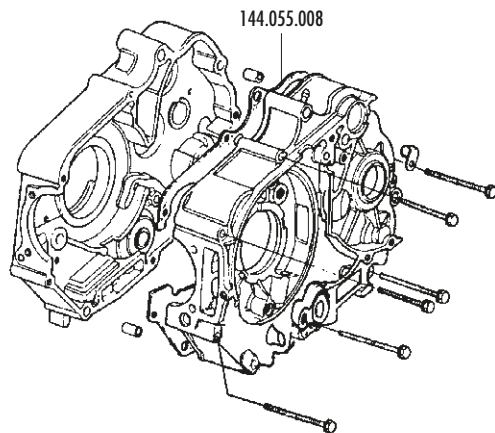

**CARTER LATO DESTRO  
ENGINE CRANKCASE-RIGHT SIDE**

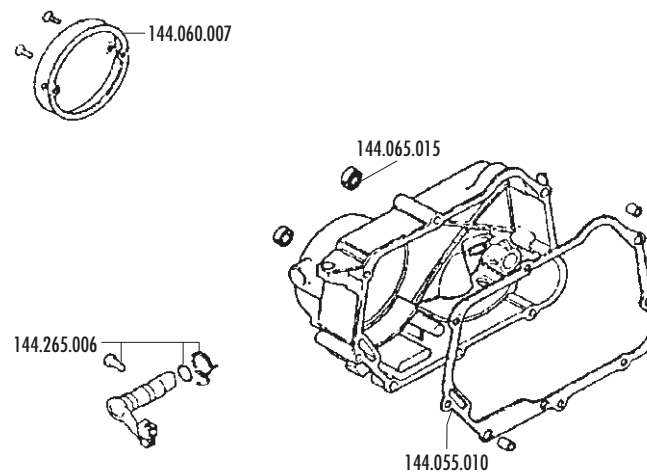

**CARTER LATO SINISTRO  
ENGINE CRANKCASE-LEFT SIDE**

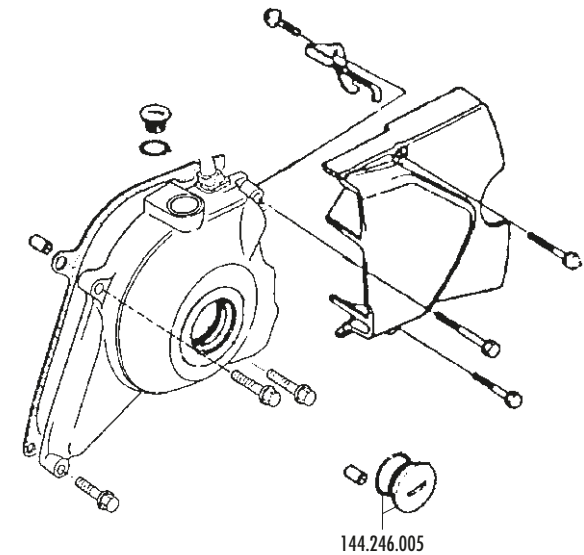

**FRIZIONE  
CLUTCH**

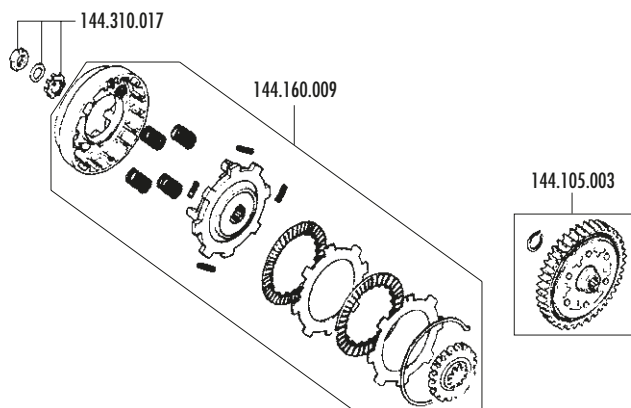

**TRASMISSIONE  
TRANSMISSION**

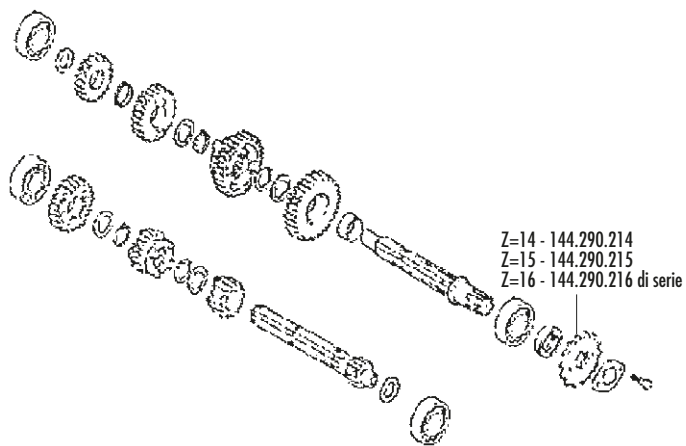

**XP4 125 c.c.  
fino al telaio - up to frame  
n° 0229  
(Gennaio - January 2007)**

**CAMME - VALVOLE  
CAM - VALVES**

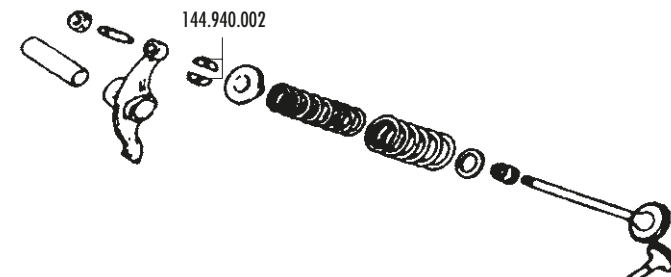

**KICK STARTER**

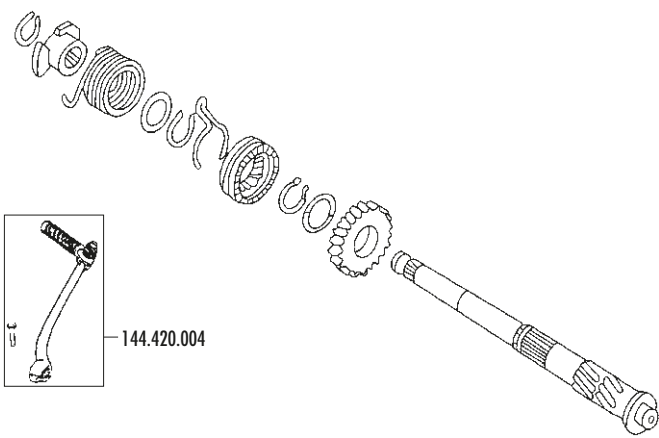

**AVVIAMENTO  
STARTER**

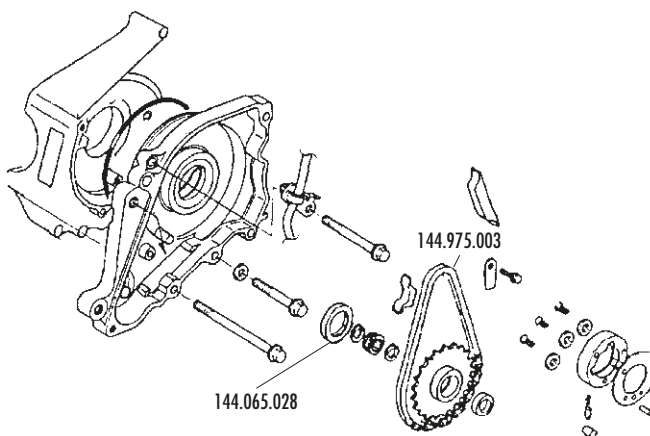

**CAMBIO  
SHIFT**

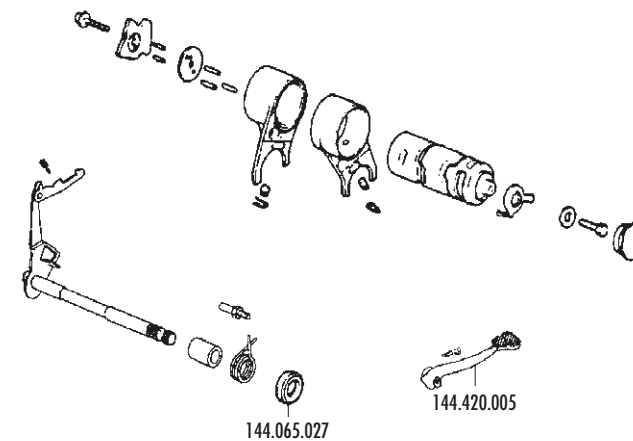

**XP4 125 c.c.**  
**dal telaio - from frame n° 0230**  
**(da Febbraio-from February 2007)**

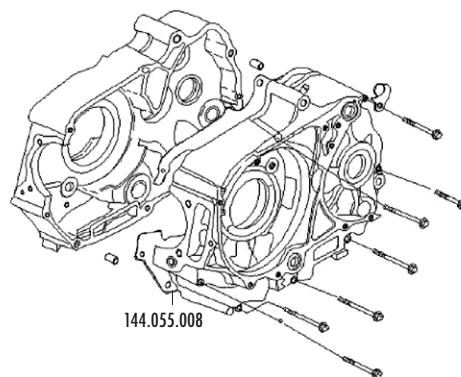
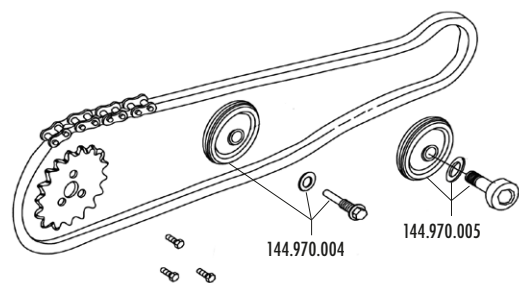
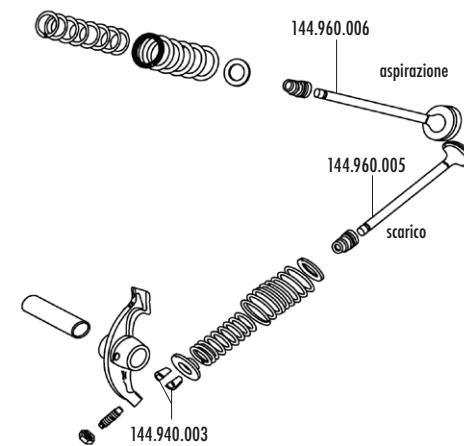
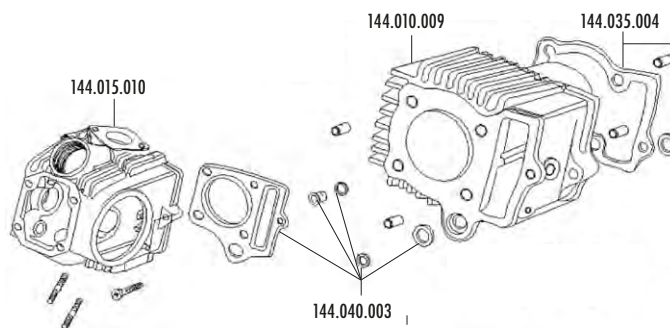
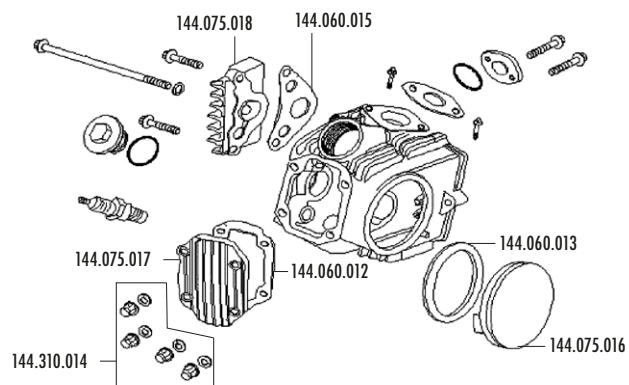

**XP4 125 c.c.**  
**dal telaio - from frame n° 0230**  
**(da Febbraio-from February 2007)**

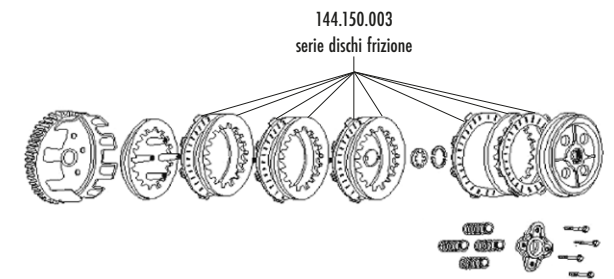
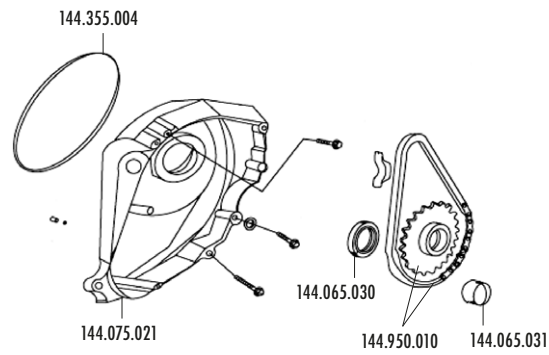
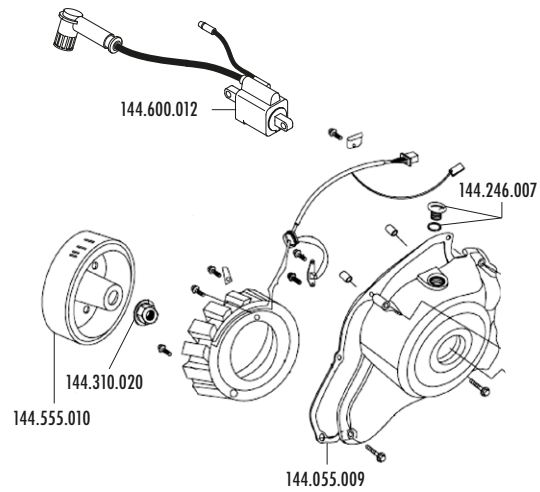
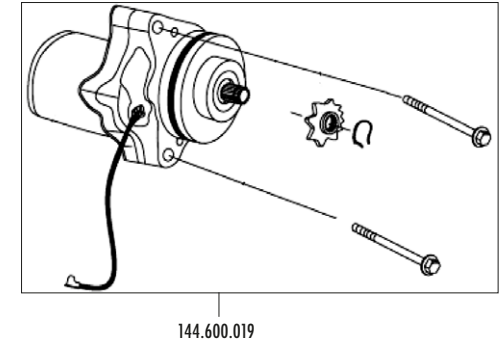
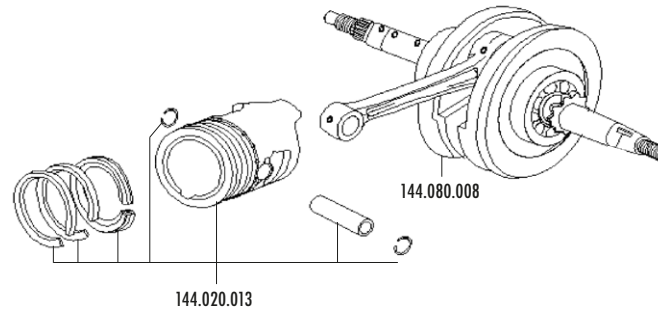
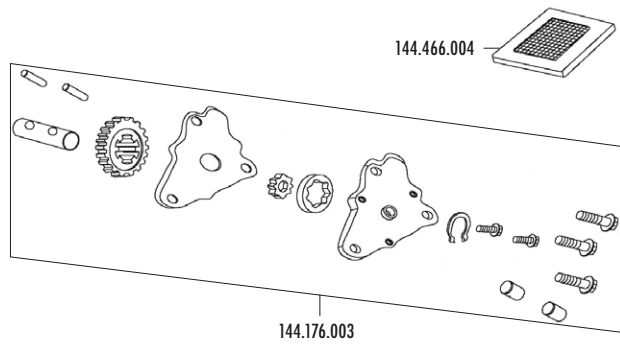

**XP4 125 c.c.  
dal telaio - from frame n° 0230  
(da Febbraio-from February 2007)**

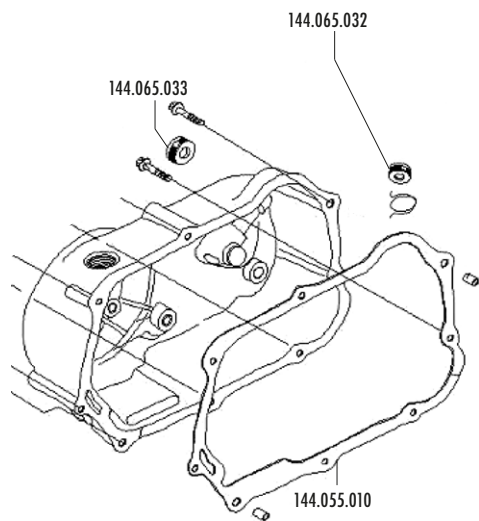

Z14= 144.290.214  
Z15= 144.290.215  
di serie Z16= 144.290.216

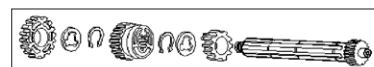

144.120.011

A+B+C= 144.112.005

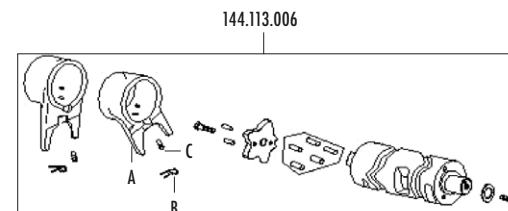

144.065.027

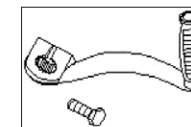

144.420.005

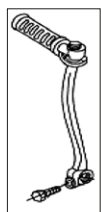

144.420.004



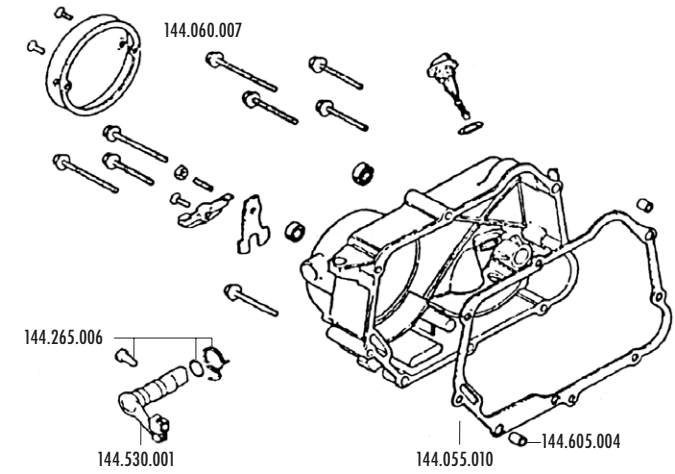
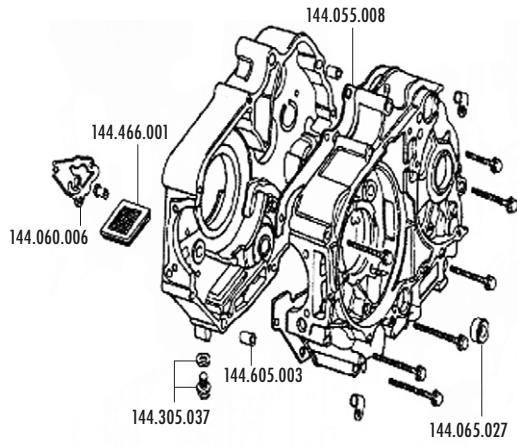
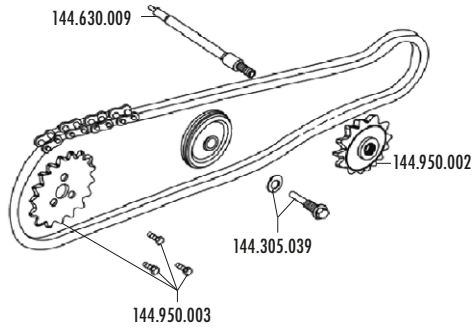
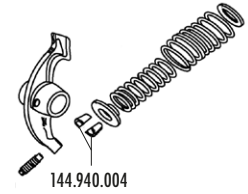
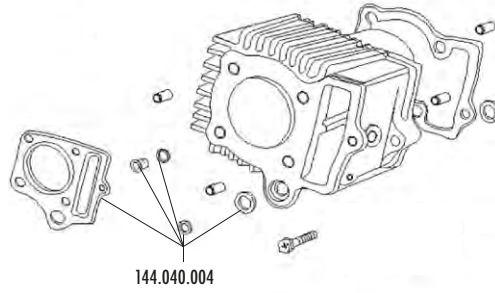
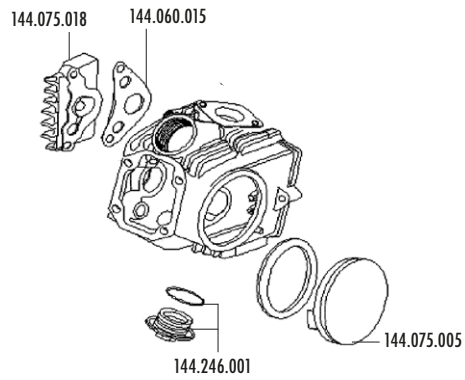

# XP 4T 50 c.c.

A+B+C= 144.112.005

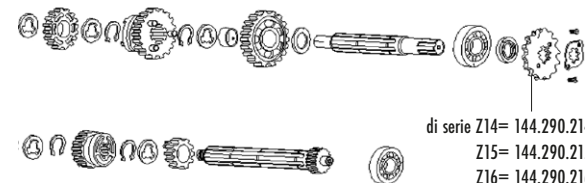
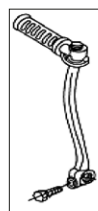
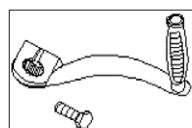
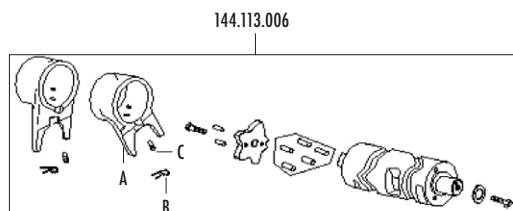

di serie Z14= 144.290.214  
 Z15= 144.290.215  
 Z16= 144.290.216

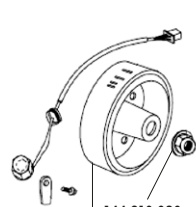
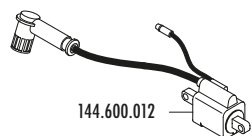

144.555.010

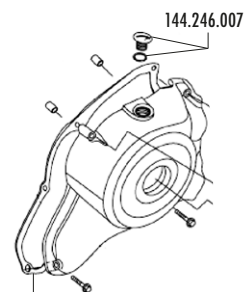

144.246.007

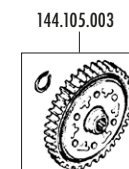
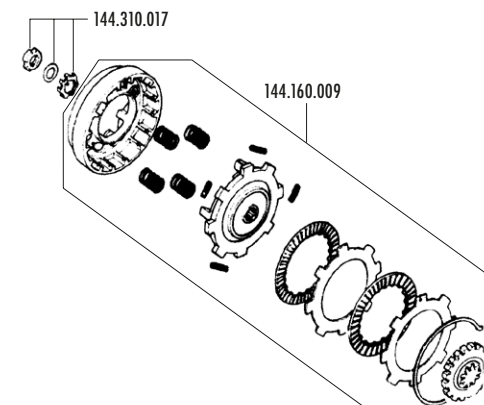
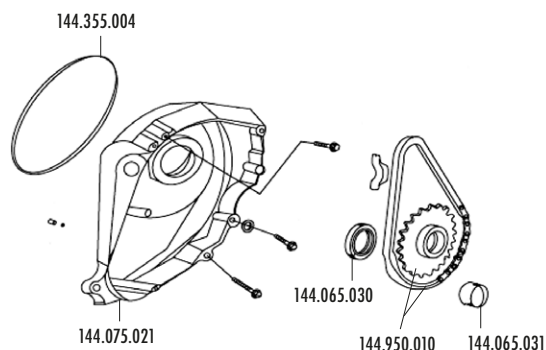

144.105.003



# XP 4T 150 c.c.

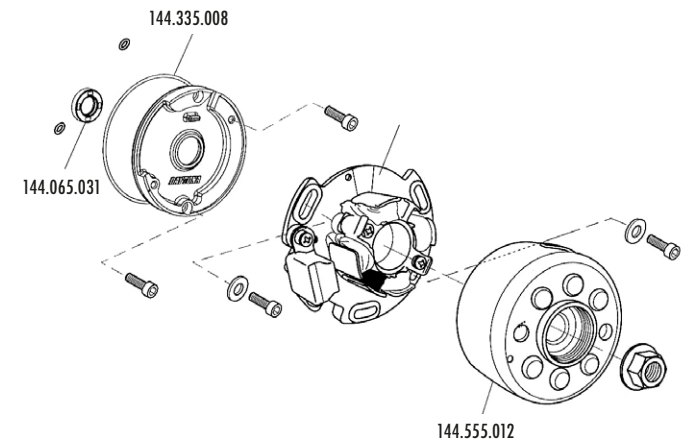
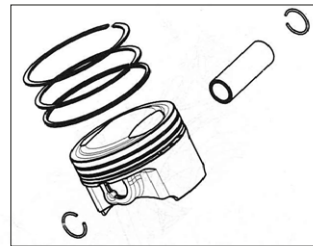
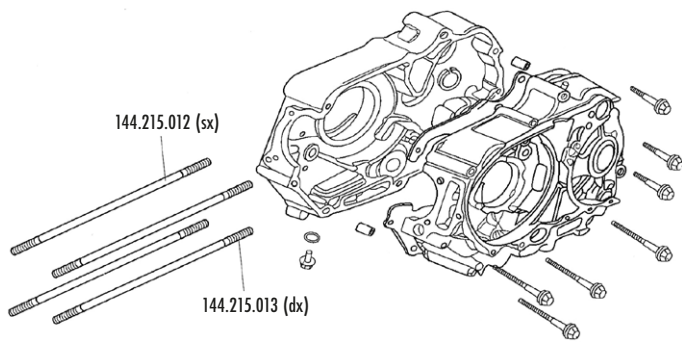
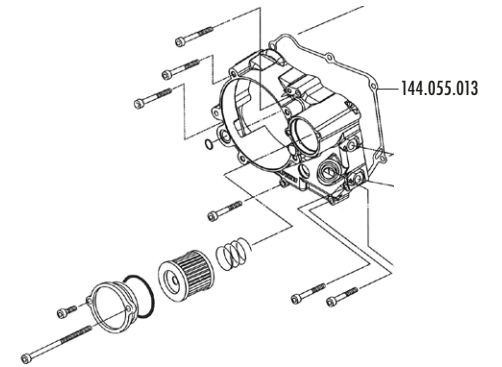
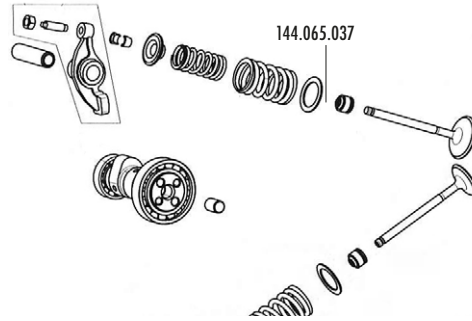
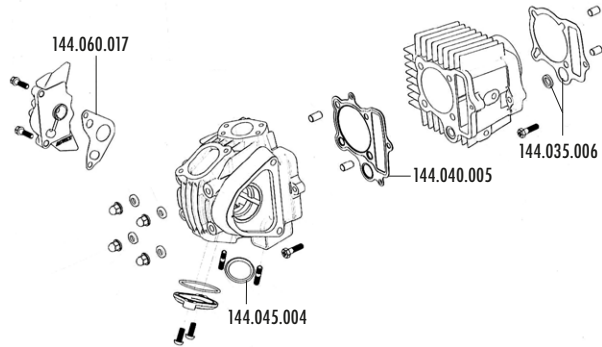

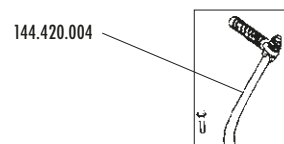
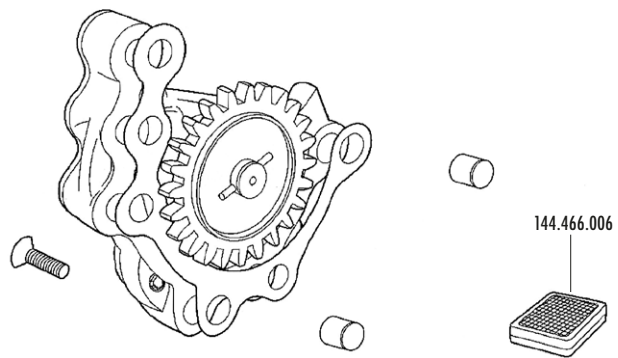

PIGNONE Z=16 144.290.216



# RICAMBI XP 65 R

## fino al telaio - up to frame

### n° 162

### ACCESSORI OPTIONALS

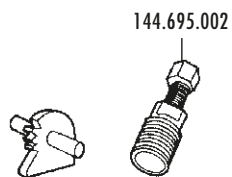

### GRUPPO TERMICO CYLINDER KIT

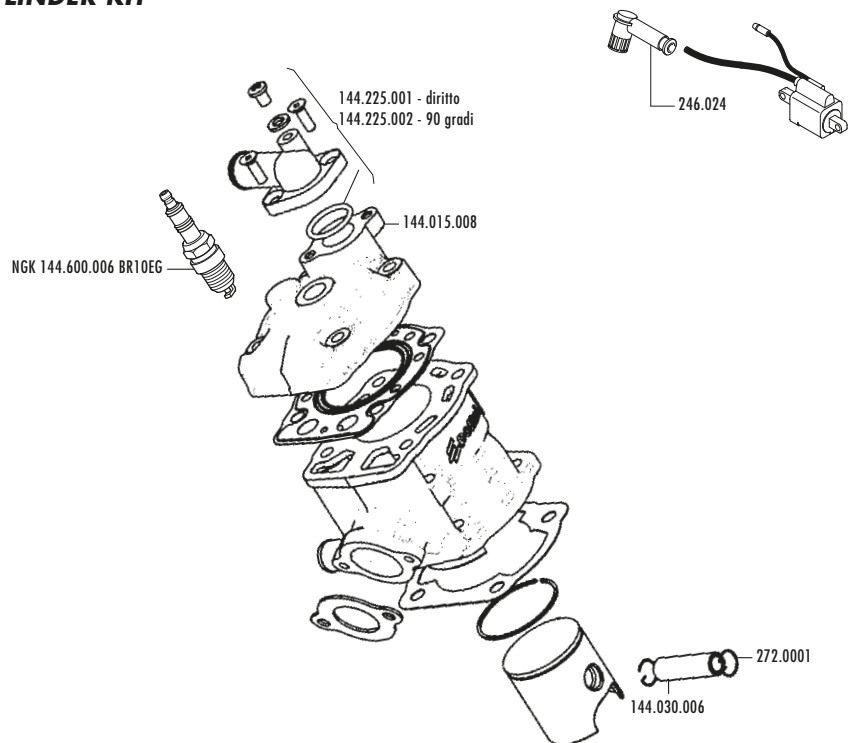

### AVVIAMENTO STARTER

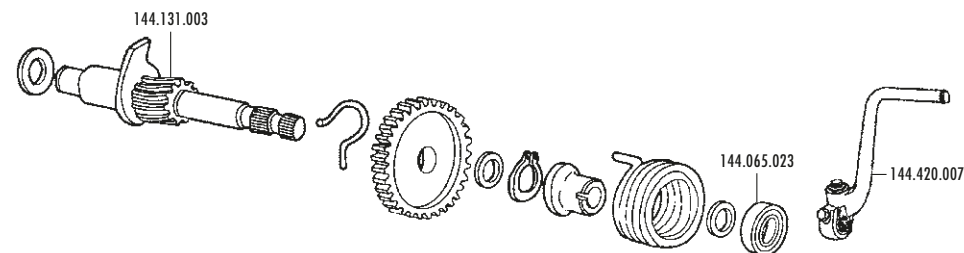

### ACCENSIONE IGNITION

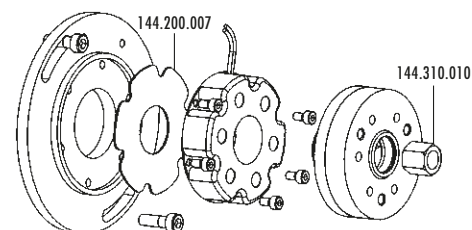

### CARTER CRANKCASE

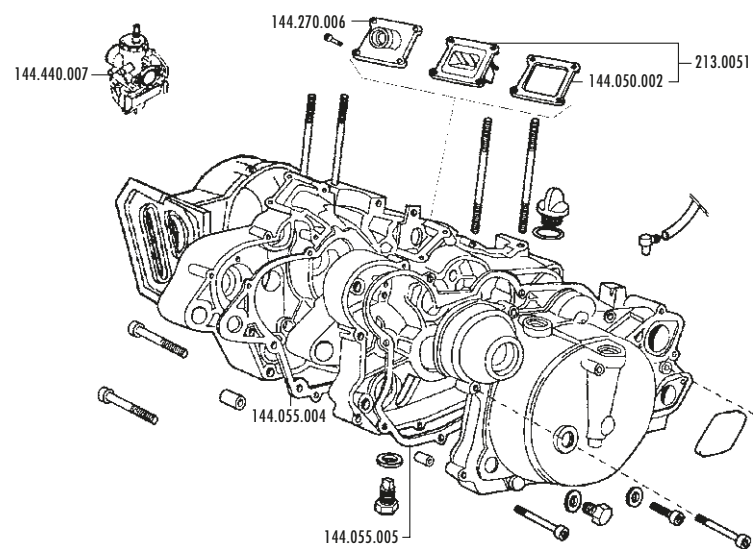

**POMPA ACQUA  
WATER PUMP**

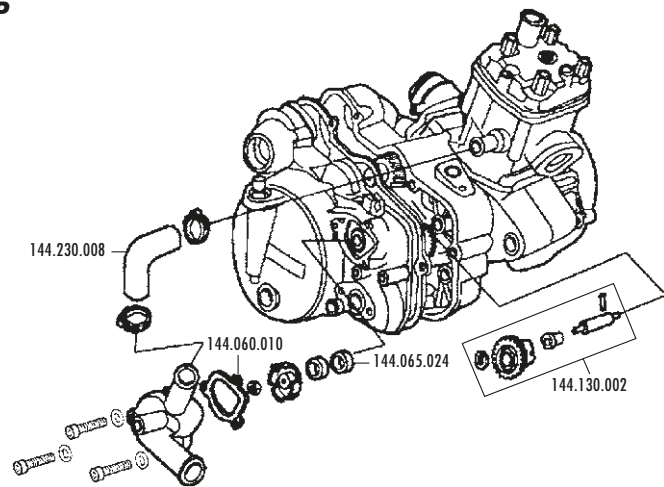

**CAMBIO  
SHIFT**

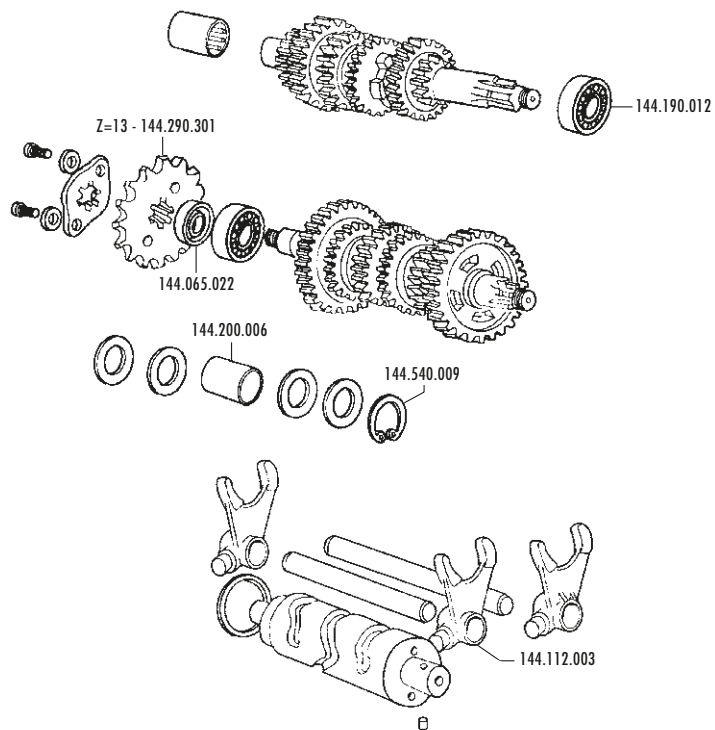

**RICAMBI XP 65 R  
fino al telaio - up to frame  
n°162**

**ALBERO MOTORE  
CRANKSHAFT**

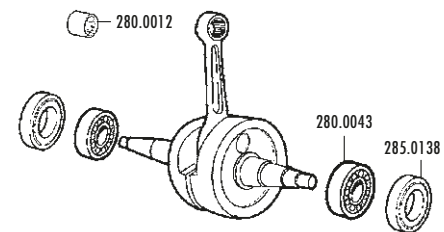

**FRIZIONE  
CLUTCH**

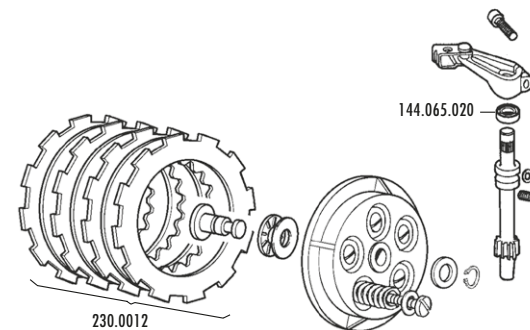

**SELETTORE CAMBIO  
SHIFT SELECTOR**

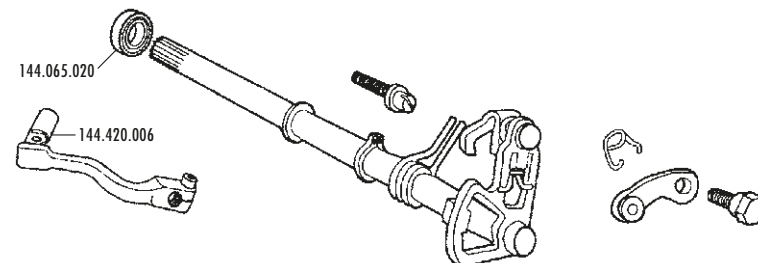

# RICAMBI XP 65 R 2008

## dal telaio - from frame n° 163

ACCESSORI  
OPTIONALS

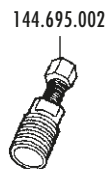

### GRUPPO TERMICO CYLINDER KIT

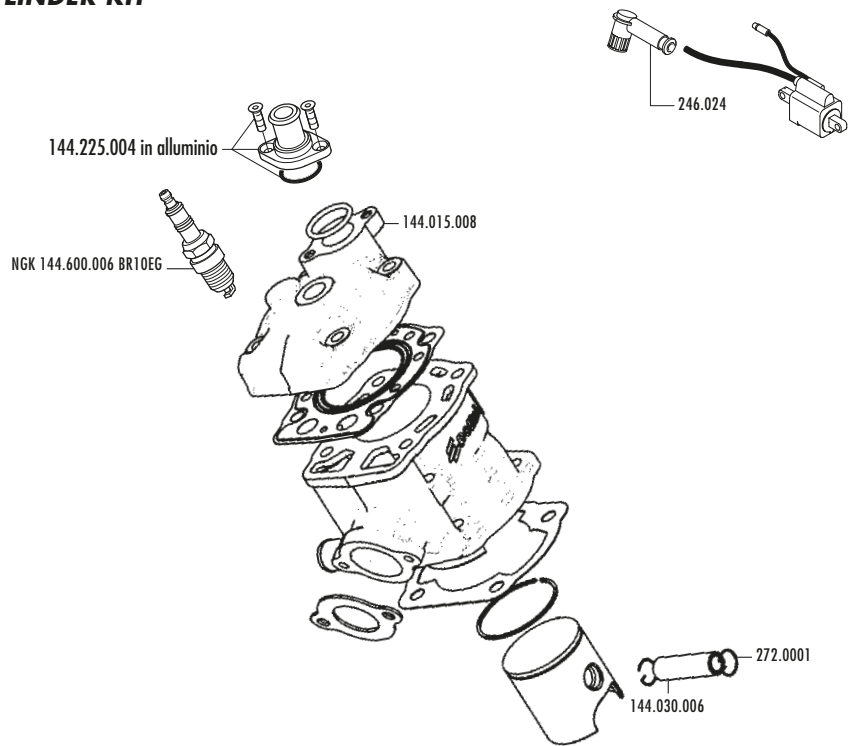

### AVVIAMENTO STARTER

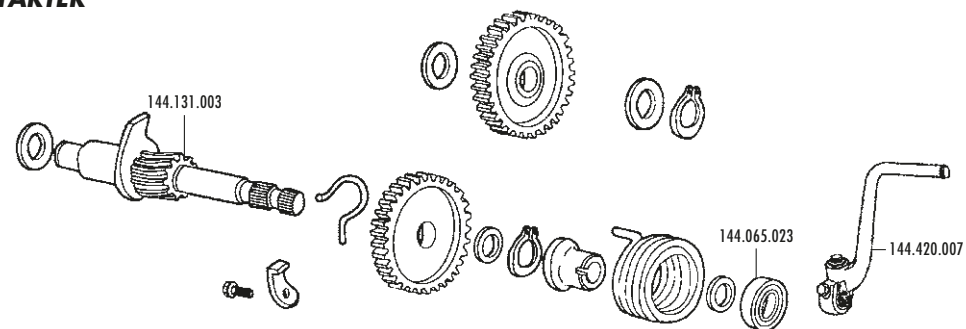

### ACCENSIONE IGNITION

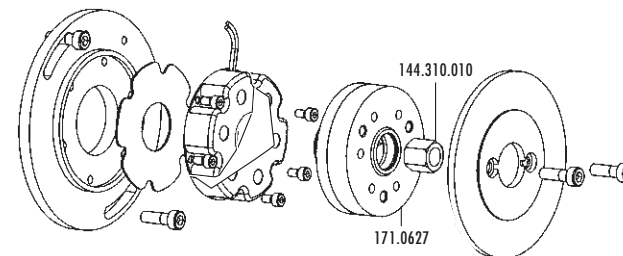

### CARTER CRANKCASE

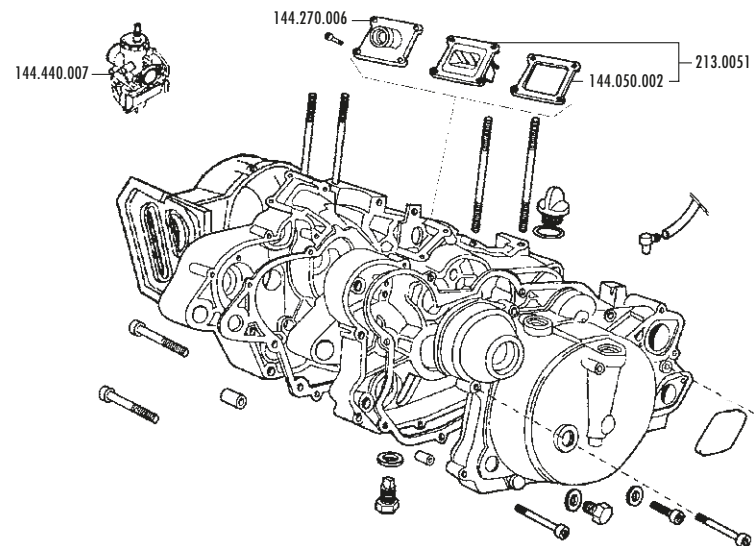

**POMPA ACQUA  
WATER PUMP**

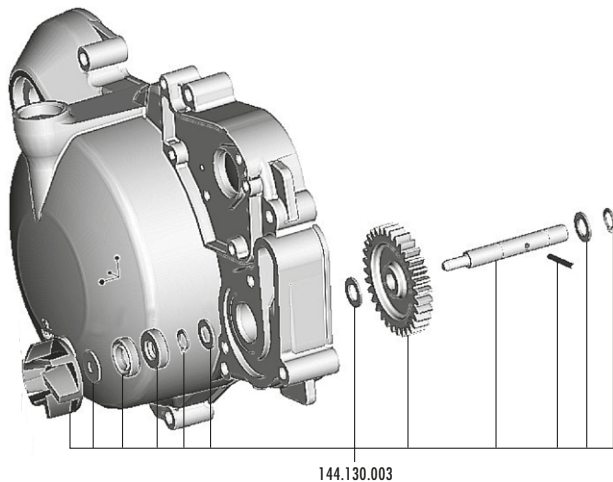

144.130.003

**CAMBIO  
SHIFT**

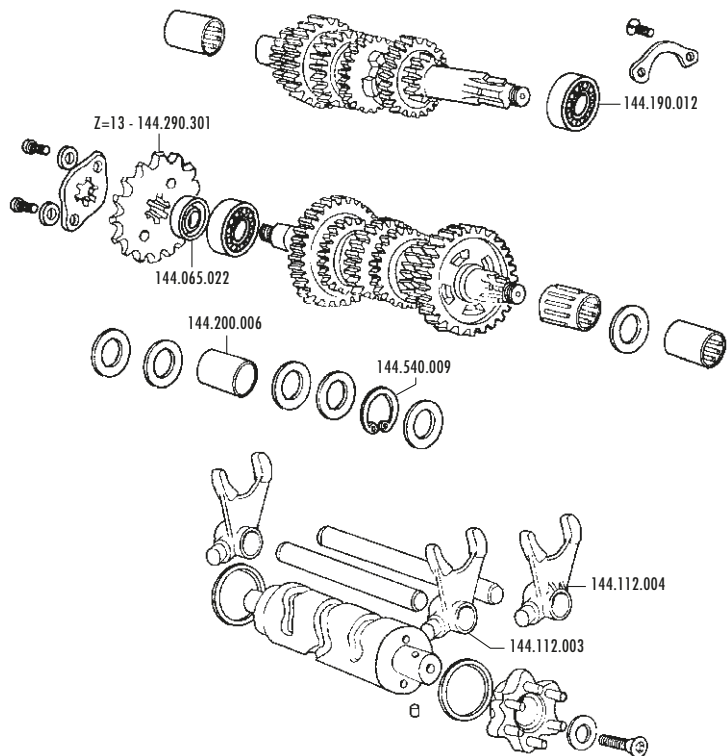

**RICAMBI XP 65 R 2008  
dal telaio - from frame n° 163**

**ALBERO MOTORE  
CRANKSHAFT**

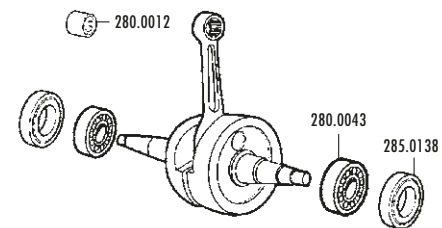

21

**FRIZIONE  
CLUTCH**

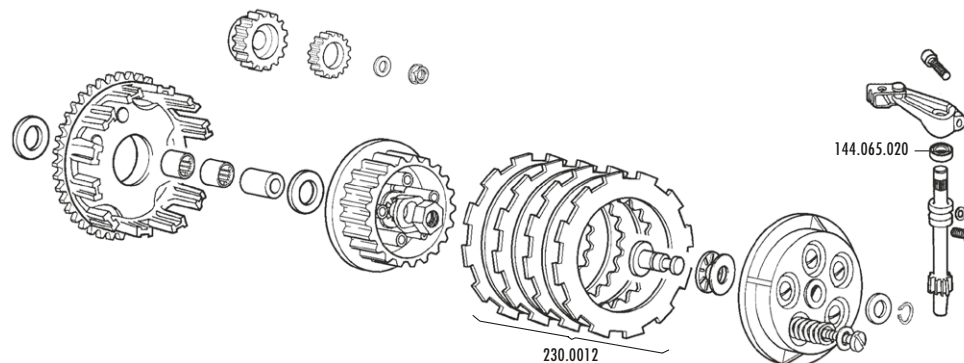

**SELETTORE CAMBIO  
SHIFT SELECTOR**

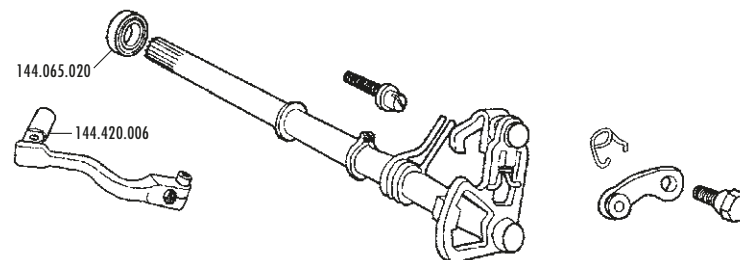

# RICAMBI POLINI CP - CP POLINI SPARE PARTS

Ø19

